



## Certificate of Analysis

Characterisation methods are accredited according to

**ISO 17025**

### Reference Material

#### Product name

2,4-Dichloro-6,7-dimethoxyquinazoline

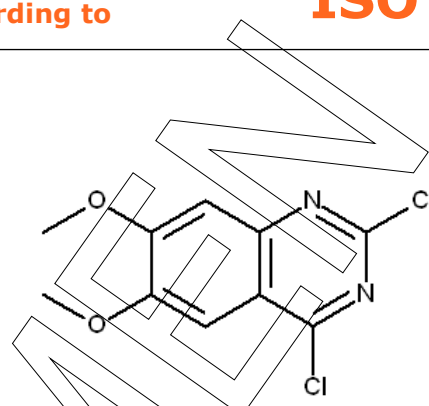

#### Product code

MM0085.06-0025

#### Lot number

W1149332

#### CAS number

27631-29-4

#### Appearance

beige solid

#### Molecular weight

259.09

#### Melting point (DSC)

176 °C

#### Molecular formula

C<sub>10</sub>H<sub>8</sub>Cl<sub>2</sub>N<sub>2</sub>O<sub>2</sub>

#### Long-term storage

2 to 8 °C, dark

Assay<sup>1</sup> "as is"  
**99.7 %**

Uncertainty<sup>2</sup> U  
**0.8 %**

**Intended Use:** Use for identification and quantification. The assay is verified by a second testing method.

Date of shipment: **08 Nov 2021**

Producer confirms that this reference material (RM) meets the specification detailed on this Certificate of Analysis for **two years** from the date of shipment, provided the substance is stored under the recommended conditions unopened in the original container.

<b>Release by:</b>	<b>Date of Release:</b>		Product Release
Dr. Sabine Schröder	Luckenwalde, 18 Oct 2021		

<sup>1</sup> Calibration and verification were carried out using standards traceable to SI-units. The value is expressed on an "as is" basis.

<sup>2</sup> The uncertainty "U" is the expanded uncertainty of the testing method for the assigned value estimated in accordance with the Guide to the Expression of Uncertainty in Measurement (GUM). It corresponds to a level of confidence of about 95%. Coverage factor k = 2.



## Product information

This RM is intended for laboratory use only and is not suitable for human or animal consumption.

This RM conforms to the characteristics of a primary standard as described in the ICH Guidelines. The values quoted in this Certificate of Analysis are the producer's best estimate of the true values within the stated uncertainties and based on the techniques described in this Certificate of Analysis. The characterisation of this material was undertaken in accordance with the requirements of ISO/IEC 17025. The identity is verified by data from international scientific literature.

## Storage and handling

Before usage of the RM, it should be allowed to warm to room temperature. No drying is required, as assigned values are already corrected for the content of water and other volatile materials.

Reference Material quality is controlled by regularly performed quality control tests (retests).

## Further content

Assigned value

Purity

Identity

Revision table

SPECIMEN



## Assigned value

**Assay "as is": 99.69 %; U = 0.82 %**

The assay "as is" is assessed by carbon titration of elemental analysis and is equivalent to the assay based on the not-anhydrous and not-dried substance. The assay is verified by 100% method (mass balance).

The verified result lies inside our acceptance criteria, i.e. less than 1.0 % difference to assay assigning technique.

For quantitative applications, use the assay as a calculation value on the "as is basis". The uncertainty of the assay can be used for estimation/calculation of measurement uncertainty.

### Method 1: Value assigning technique - carbon titration of elemental analysis

<b>Method</b>	percentage carbon found in relation to percentage carbon as calculated for molecular formula
<b>Result</b> (mass fraction, n = 3)	99.69 %; U = 0.82 %

### Method 2: Value verifying technique - 100% method

<b>100% method (mass balance) with chromatographic purity by HPLC</b>	
<b>Result</b>	99.72 %

The calculation of the 100% method follows the formula:

$$\text{Assay (\%)} = (100\% - \text{volatile contents (\%)}) * \frac{\text{Purity (\%)}}{100\%}$$

Volatile contents are considered as absolute contributions and purity is considered as relative contribution. Inorganic residues are excluded by additional tests.



## Purity

### Purity by high performance liquid chromatography (HPLC)

HPLC Conditions:	
Column	Hypersil Gold C18; 5 $\mu$ m, 150 x 4.6 mm
Column temperature	40 °C
Detector	DAD, 250 nm
Injector	Auto 5 $\mu$ l; 0.0406 mg/ml in Acetonitrile/Water 50/50 (v/v)
Flow rate	1.0 ml/min
Phase A	Water, 0.1 % H <sub>3</sub> PO <sub>4</sub>
Phase B	Acetonitrile, 0.1 % H <sub>3</sub> PO <sub>4</sub>
Gradient program	0-12 min A/B 60/40 12-17 min A/B to 20/80 17-22 min A/B 20/80 22-25 min A/B to 60/40 25-35 min A/B 60/40 (v/v)

HPLC chromatogram and peak table

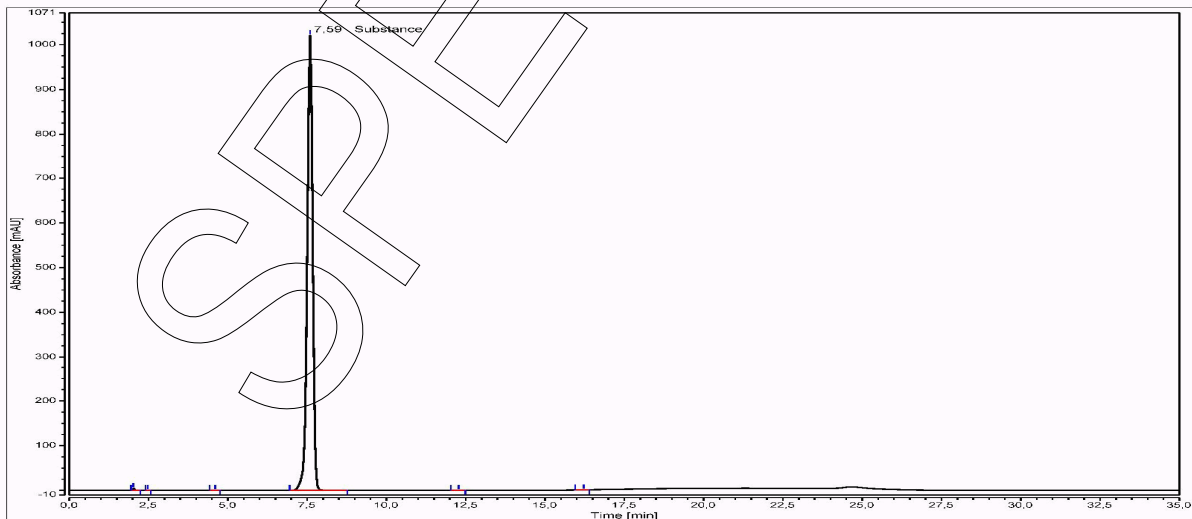



## Area percent report - sorted by signal

Pk #	Retention time	Area	Area %
1	2.025	0.2888	0.14
2	2.480	0.0323	0.02
3	4.597	0.0283	0.01
4	7.593	204.1281	99.79
5	12.277	0.0162	0.01
6	16.222	0.0692	0.03
<b>Totals</b>		<b>204.5629</b>	<b>100.00</b>

The content of the analyte was determined as ratio of the peak area of the analyte and the cumulative areas of the purities, added up to 100 %. System peaks were ignored in calculation.

**Result (n = 6)** 99.80 %; U = 0.18 %

### Volatile content

#### Water content

**Method** Karl Fischer titration  
**Result (n = 3)** 0.08 %; U = 0.04 %

#### Residual solvents

**Method** <sup>1</sup>H-NMR  
**Result (n = 1)** No significant amounts of residual solvents were detected (< 0.05 %).\*

\*not accredited testing method



**Inorganic residues**

**Method:** Elementary analysis

Inorganic residues can be excluded by elementary analysis (CHN).

SPECIMEN



## Identity

The identity is assessed by ISO/IEC 17025 accredited testing methods.

Method	Conditions	Result
<sup>1</sup> H-NMR	400 MHz, DMSO-d <sub>6</sub>	Structure confirmed

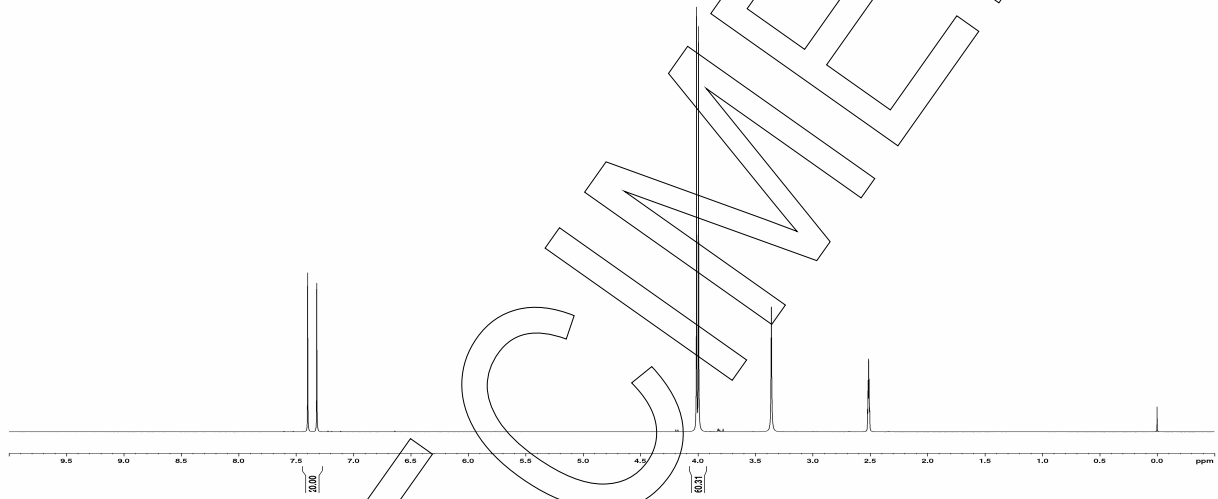



Method	Conditions	Result
<sup>13</sup> C-NMR	100 MHz, DMSO-d <sub>6</sub>	Structure confirmed

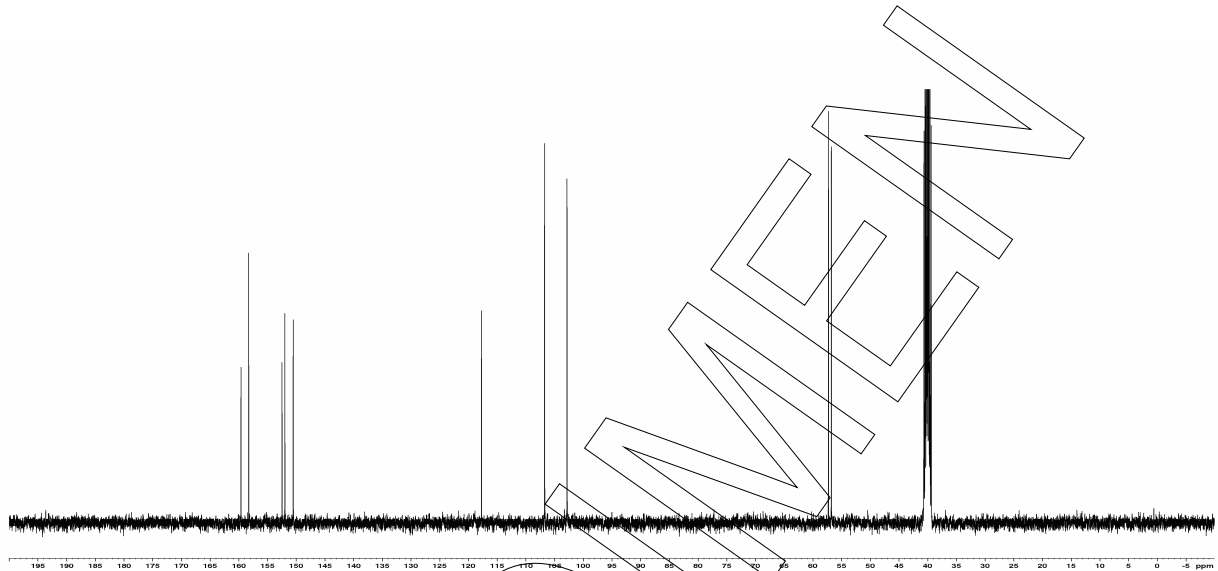

SPECIMEN





Method	Conditions	Result
MS	3.5 kV ESI+; capillary temperature: 269 °C Theoretical value: 259.00356	Structure confirmed



SPECIMEN



Method	Conditions	Result
IR	Attenuated Total Reflection Fourier Transform Infrared (ATR-FTIR) Spectroscopy	Structure confirmed

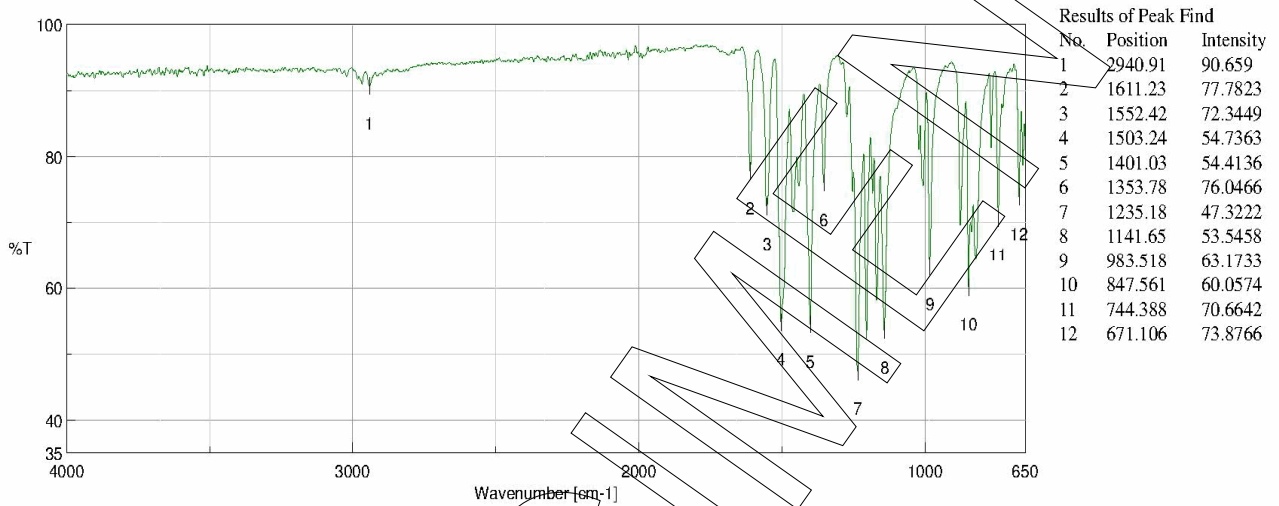

## Revision table

Revision	Date	Reason for revision
00	18 Oct 2021	Release of the Certificate of Analysis - initial version

Product warranties for the RM are set out in the terms and conditions of purchase.